

HCL-Series, Single-Acting, Gravity Return Cylinders

- Lock nut provides positive and safe mechanical load holding
- Low-friction locking rings spin easy, save time and effort
- Designed to withstand 10% side-load up to 90% of maximum stroke
- Hardened surface resists side-loading and cyclic wear
- Overflow port as stroke limiter to prevent plunger blow-out
- Weather protected, inside and out
- Replaceable bearings enclose the plunger for support throughout the stroke
- Certified lifting eyes and base mounting holes.

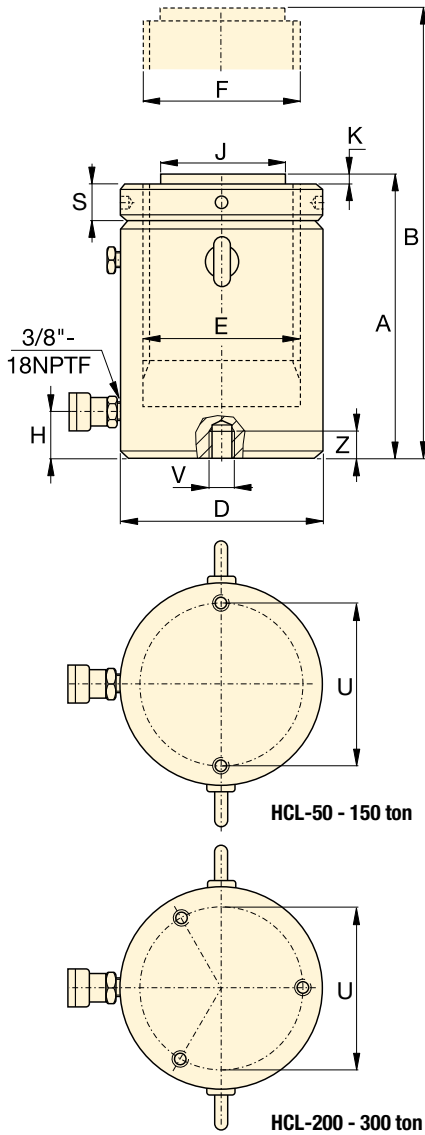

SELECTION CHART 50 - 300 TON HCL-MODELS

For 400 - 1000 ton models, see pages 56-57.

For full product features see pages 42-43.

Cylinder Capacity	Stroke	Model Number	Maximum Cylinder Capacity at 700 bar ton (kN)	Cylinder Effective Area	Oil Capacity	Collapsed Height
ton	(mm)			(cm ²)	(cm ³)	A (mm)
50	50	HCL-502	56 (550)	78,5	393	164
	100	HCL-504			785	214
	150	HCL-506			1178	264
	200	HCL-508			1571	314
	250	HCL-5010			1963	364
	300	HCL-5012			2356	414
100	50	HCL-1002	102 (1002)	143,1	716	187
	100	HCL-1004			1431	237
	150	HCL-1006			2147	287
	200	HCL-1008			2863	337
	250	HCL-10010			3578	387
	300	HCL-10012			4294	437
150	50	HCL-1502	153 (1497)	213,8	1069	209
	100	HCL-1504			2138	259
	150	HCL-1506			3207	309
	200	HCL-1508			4276	359
	250	HCL-15010			5346	409
	300	HCL-15012			6415	459
200	50	HCL-2002	202 (1985)	283,5	1418	238
	100	HCL-2004			2835	288
	150	HCL-2006			4253	338
	200	HCL-2008			5671	388
	250	HCL-20010			7088	438
	300	HCL-20012			8506	488
250	50	HCL-2502	259 (2541)	363,1	1815	249
	100	HCL-2504			3631	299
	150	HCL-2506			5446	349
	200	HCL-2508			7261	399
	250	HCL-25010			9076	449
	300	HCL-25012			10.892	499
300	50	HCL-3002	310 (3036)	433,7	2169	278
	100	HCL-3004			4337	328
	150	HCL-3006			6506	378
	200	HCL-3008			8675	428
	250	HCL-30010			10.843	478
	300	HCL-30012			13.012	528

Base Mounting Holes (mm)					
Model / Capacity ton	Bolt Circle U	Thread Size V	Minimum Thread Depth Z	Number of Holes	Angle from Coupler
HCL-50	105	M8 x 1,25	10	2	90°
HCL-100	150	M12 x 1,75	17	2	90°
HCL-150	185	M12 x 1,75	22	2	90°
HCL-200	215	M12 x 1,75	22	3	60°
HCL-250	245	M12 x 1,75	22	3	60°
HCL-300	260	M16 x 2	25	3	60°

Single-Acting, Lock Nut Cylinders

Capacity:
50 - 300 ton

Stroke:
50 - 300 mm

Maximum Operating Pressure:
700 bar

HCL Series

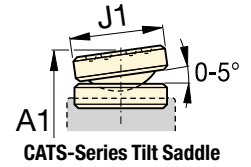

Extended Height	Outside Diameter	Cylinder Bore Diameter	Plunger Diameter (threaded)	Base to Advance Port	Standard Saddle Diameter	Saddle Protrusion from Plunger	Lock Nut Height	Model Number	Optional Tilt Saddle				
									Saddle Diameter J1 (mm)	Collapsed Height * A1 (mm)	Saddle Model Number		
214	130	100	Tr 100 x 4	24	71	2	25	17	HCL-502	71	174	CATS-100	
314								22					224
414								27					274
514								32					324
614								38					374
714								43					424
237	175	135	Tr 135 x 6	33	71	2	33	35	HCL-1002	71	197	CATS-100	
337								44					247
437								54					297
537								63					347
637								73					397
737								82					447
259	215	165	Tr 165 x 6	41	130	2	40	59	HCL-1502	126	225	CATS-201	
359								73					275
459								87					325
559								102					375
659								116					425
759								130					475
288	250	190	Tr 190 x 6	47	130	2	45	85	HCL-2002	126	254	CATS-201	
388								105					304
488								124					354
588								143					404
688								163					454
788								182					504
299	280	215	Tr 215 x 6	53	140	2	52	119	HCL-2502	175	288	CATS-300	
399								143					338
499								167					388
599								192					438
699								216					488
799								240					538
328	305	235	Tr 235 x 6	58	140	2	56	158	HCL-3002	175	317	CATS-300	
428								186					367
528								215					417
628								244					467
728								272					517
828								301					567

* A1 = Collapsed height including CATS-Series tilt saddle.

HCL-Series, Single-Acting, Gravity Return Cylinders

- Lock nut provides positive and safe mechanical load holding
- Low-friction locking rings spin easy, save time and effort
- Designed to withstand 10% side-load up to 90% of maximum stroke
- Hardened surface resists side-loading and cyclic wear
- Overflow port as stroke limiter to prevent plunger blow-out
- Weather protected, inside and out
- Replaceable bearings enclose the plunger for support throughout the stroke
- Certified lifting eyes and base mounting holes.

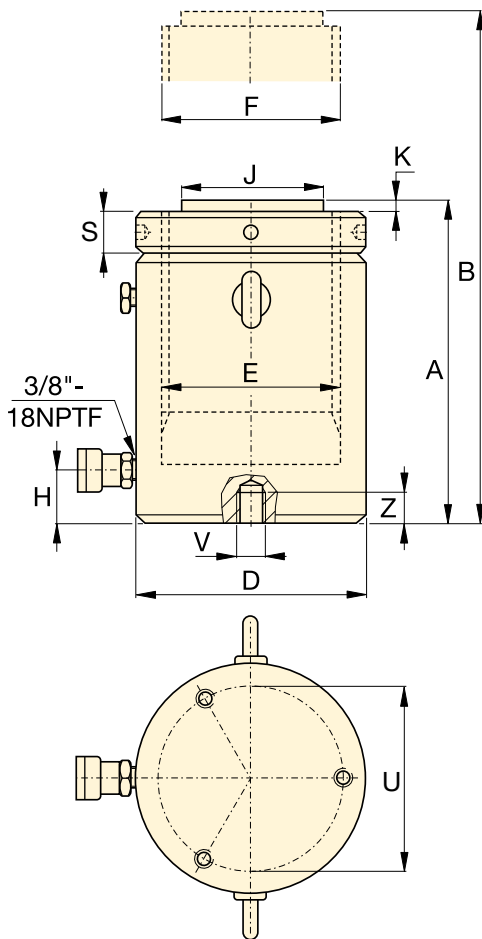

SELECTION CHART 400 - 1000 TON HCL-MODELS

For 50 - 300 ton models, see pages 54-55.

For full product features see pages 42-43.

Cylinder Capacity	Stroke	Model Number	Maximum Cylinder Capacity at 700 bar	Cylinder Effective Area	Oil Capacity	Collapsed Height
ton	(mm)		ton (kN)	(cm ²)	(cm ³)	A (mm)
400	50	HCL-4002	409 (4008)	572,6	2863	317
	100	HCL-4004			5726	367
	150	HCL-4006			8588	417
	200	HCL-4008			11.451	467
	250	HCL-40010			14.314	517
	300	HCL-40012			17.177	567
500	50	HCL-5002	522 (5114)	730,6	3653	357
	100	HCL-5004			7306	407
	150	HCL-5006			10.959	457
	200	HCL-5008			14.612	507
	250	HCL-50010			18.265	557
	300	HCL-50012			21.918	607
600	50	HCL-6002	611 (5987)	855,3	4276	380
	100	HCL-6004			8553	430
	150	HCL-6006			12.829	480
	200	HCL-6008			17.106	530
	250	HCL-60010			21.382	580
	300	HCL-60012			25.659	630
800	50	HCL-8002	831 (8149)	1164,2	5821	430
	100	HCL-8004			11.642	480
	150	HCL-8006			17.462	530
	200	HCL-8008			23.283	580
	250	HCL-80010			29.104	630
	300	HCL-80012			34.925	680
1000	50	HCL-10002	1085 (10.644)	1520,5	7603	484
	100	HCL-10004			15.205	534
	150	HCL-10006			22.808	584
	200	HCL-10008			30.411	634
	250	HCL-100010			38.013	684
	300	HCL-100012			45.616	734

Base Mounting Holes (mm)					
Model / Capacity ton	Bolt Circle U	Thread Size V	Minimum Thread Depth Z	Number of Holes	Angle from Coupler
HCL-400	300	M16 x 2	25	3	60°
HCL-500	340	M24 x 3	36	3	60°
HCL-600	370	M24 x 3	36	3	60°
HCL-800	440	M24 x 3	36	3	60°
HCL-1000	500	M24 x 3	36	3	60°

Single-Acting, Lock Nut Cylinders



▲ Heavy lifting and foundation levelling. The lock nut provides mechanical load holding over a long period of time.

HCL Series



Capacity:
400 - 1000 ton

Stroke:
50 - 300 mm

Maximum Operating Pressure:
700 bar

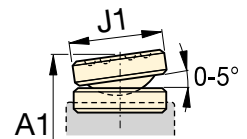

CATS-Series Tilt Saddle

Extended Height B (mm)	Outside Diameter D (mm)	Cylinder Bore Diameter E (mm)	Plunger Diameter (threaded) F (mm)	Base to Advance Port H (mm)	Standard Saddle Diameter J (mm)	Saddle Protrusion from Plunger K (mm)	Lock Nut Height S (mm)	 (kg)	Model Number	Optional Tilt Saddle			
										Saddle Diameter J1 (mm)	Collapsed Height * A1 (mm)	Model Number	
367	350	270	Tr 270 x 6	67	159	5	65	236	HCL-4002	210	365	CATS-400	
467								274	HCL-4004				415
567								311	HCL-4006				465
667								349	HCL-4008				515
767								387	HCL-40010				565
867								425	HCL-40012				615
407	400	305	Tr 305 x 6	75	179	5	72	341	HCL-5002	230	405	CATS-500	
507								390	HCL-5004				455
607								439	HCL-5006				505
707								489	HCL-5008				555
807								538	HCL-50010				605
907								587	HCL-50012				655
430	430	330	Tr 330 x 6	81	194	5	80	427	HCL-6002	250	433	CATS-600	
530								484	HCL-6004				483
630								541	HCL-6006				533
730								598	HCL-6008				583
830								655	HCL-60010				633
930								712	HCL-60012				683
480	505	385	Tr 385 x 6	95	224	5	90	668	HCL-8002	275	487	CATS-800	
580								746	HCL-8004				537
680								825	HCL-8006				587
780								904	HCL-8008				637
880								982	HCL-80010				687
980								1061	HCL-80012				737
534	570	440	Tr 440 x 6	110	249	5	105	959	HCL-10002	300	561	CATS-1000	
634								1059	HCL-10004				611
734								1160	HCL-10006				661
834								1260	HCL-10008				711
934								1360	HCL-100010				761
1034								1460	HCL-100012				811

* A1 = Collapsed height including CATS-Series tilt saddle.